

REV	DATE	REVISION DETAILS	APPD
A	Jun.12.2017	Production issue	

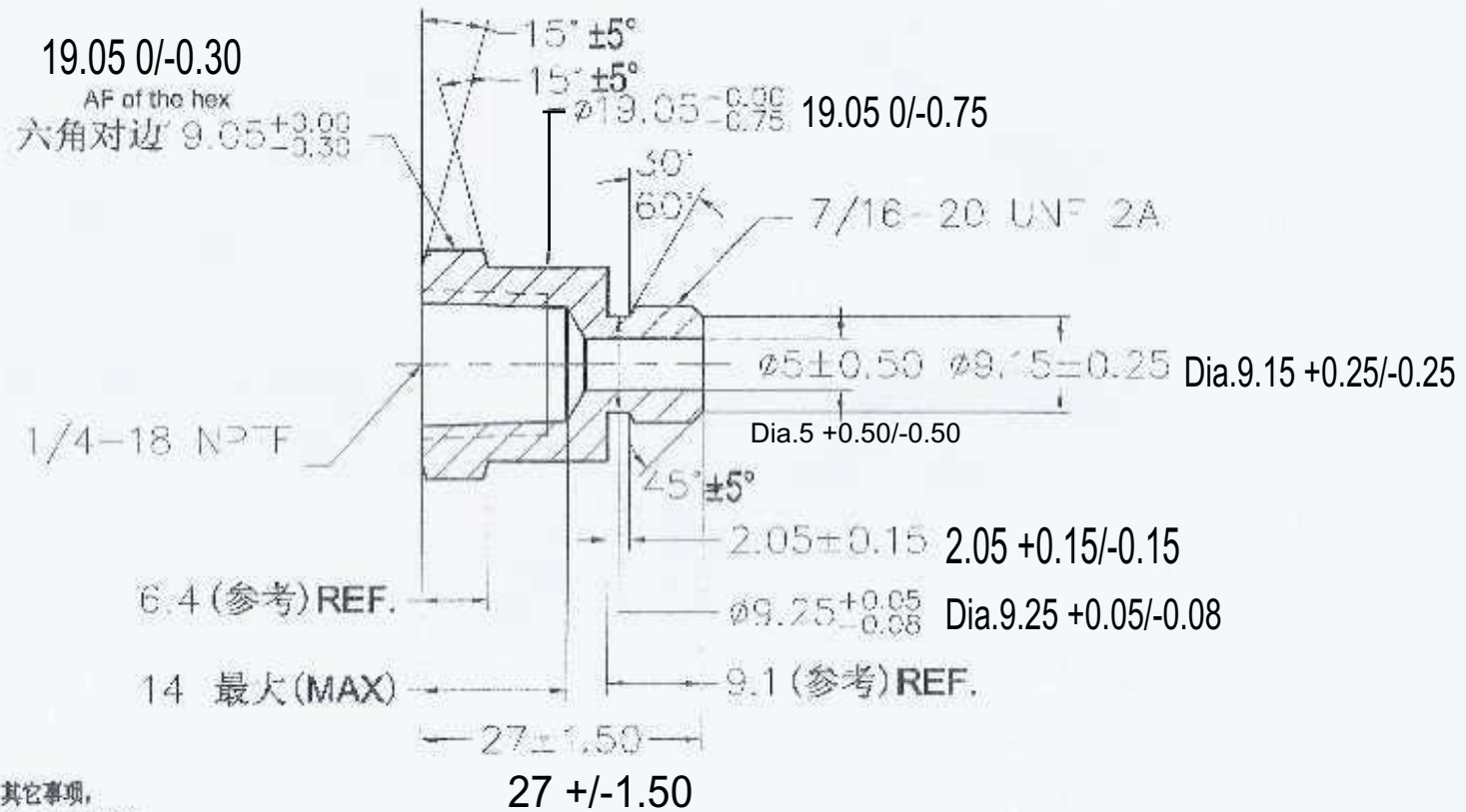

UNLESS SPECIFIED
ALL DIMENSIONS IN mm,
MACHINED SURFACES Ra=3.2um,
ANGLE TOLERANCES ±1°,
Other tolerance except angles,
in accordance with
GB/T1804-2000(ISO2768-1)-m
and GB/T1184-1996(ISO2768-2)-m

其它事项,
图示尺寸单位为mm,
未注机加工表面粗糙度 Ra=3.2um,
未注角度公差 ±1°,
其它未注公差 (除角度外) 均按:
GB/T1804-2000(ISO2768-1)-m 和
GB/T1184-1996(ISO2768-2)-m

Yuhuan Getal Machinery Co., Ltd.

PART No 零件名	41252-4-4NPTF		
SCALE:	APPD: 批准 Zhang	DRN: 制图 Pande	2017.08.08
NTS	DATE: 日期 12/06/17	CHK: 审核 Pande	2017.08.08

MATERIAL Chinese steel 45

FINISH Remove all sharp edges,burrs,filfers and swarf, break all edges D.127-0.254mm.
Surface plating with minimum thickness 60microns and protect chromate passivation or 10-15microns of blue to white / 140 hrs to red rust in salt spray test.

去除所有毛刺, 铁屑等残物, 锐边倒钝 R.127-0.254mm.
镀三价铬钝化, 膜白色, 盐雾试验48小时无白锈, 144小时无红锈